

HVJ Envelope VECTOR KIT

GenomONE™-Neo EX

Instruction Manual (Ver 1.05)

Precautions for use	2
1. Outline	3
1-1 : Principle of transfection	3
1-2 : Specifications.....	3
2. Methods described in this package insert.....	5
2-1 : Definition of quantity (AU : Assay Unit)	5
2-2 : Recommended cell density for each plate size.....	5
2-2-1 : Adherent cells.....	5
2-2-2 : Suspension cells.....	5
3. Transfection of adherent cells.....	6
3-1 : Transfer of plasmid DNA	6
3-1-1 : Recommended protocol	6
3-1-2 : Protocol for use of low concentrations of DNA	7
3-2 : Transfer of siRNA	8
3-3 : Transfer of antisense oligo/decoy-oligo (ODN)	9
3-4 : Transfer of protein.....	10
3-5 : Troubleshooting	11
4. Transfection of suspension cells	12
4-1 : Transfer of plasmid DNA	12
4-1-1 : Recommended protocol	12
4-1-2 : Protocol for use of low concentrations of DNA	13
4-2 : Transfer of siRNA	14
4-3 : Transfer of antisense oligo/decoy-oligo (ODN)	15
4-4 : Transfer of protein.....	16
4-5 : Troubleshooting	17
5. Transfection of laboratory animals (<i>in vivo</i>).....	18
5-1 : Transfer of plasmid DNA or siRNA.....	18
5-2 : Transfer of antisense oligo/decoy-oligo (ODN) or protein.....	19
6. Rapid transfection for multiple types of and numerous samples	20
6-1 : Transfer of plasmid DNA	20
6-2 : Transfer of siRNA	21

I This product is for use in laboratory research. It has not been approved for *in vitro* or *in vivo* use for the diagnosis or treatment of a patient and the seller advises against any such use.
I This package insert describes standard methods to be used with GenomONE™-Neo EX for transfection with genes, proteins, etc. The methods described here yield reasonable efficiency of transfection, though optimal conditions of transfection can vary depending on cell type. It is advisable to optimize the conditions of transfection, referring to the precautions listed in this package insert.

Precautions for use

1. **This product is sold for research purpose only. It may not be used for treatment or other clinical purposes or for intra- and extracorporeal diagnosis in humans or animals.**
2. When using this product for recombinant DNA experiments, rules for recombinant DNA experiments (stipulated in relevant statutes in the country of use or set forth by the safety committee of the facility concerned) must be followed, and experiments should only be carried out in laboratories properly equipped with facilities appropriate for recombinant DNA experiments.
3. Experiments using this product must only be carried out by investigators who have been trained in laboratory techniques and have knowledge of and skill in cell culture and genetic engineering.
4. Laboratory staff members working in the area where HVJ-E experiments are occurring should be informed of the properties of HVJ-E, in order to prevent accidents arising from inappropriate handling of it.
5. Although the HVJ (Sendai virus) contained in the HVJ envelope (HVJ-E) of this kit has been inactivated to completely eliminate its proliferative and infective potential, it retains membrane-fusion activity. Therefore, to prevent inhalation, attachment, unintended swallowing, or spread to eyes or nose of the HVJ-E particles, the product must be manipulated within a safety cabinet, wearing appropriate clothing (laboratory overalls) and protective items (plastic or latex gloves, mask, protective eyeglasses, etc.).
6. Do not pipette HVJ-E by mouth. Avoid splashing or generation of aerosols. Avoid contact of skin or mucous membranes with HVJ-E and other kit reagents. In the case of contact with skin or eyes, wash immediately with water. Membrane-fusion activity of HVJ-E is inactivated by autoclaving or treatment with detergent or 70% ethanol.
7. Empty containers of HVJ-E and tools and devices exposed to HVJ-E (pipettes, dishes, chips, etc.) must be handled carefully and disposed of after being autoclaved.
8. Although none of the other reagents contained in the kit is a toxic or powerful substance, they should be handled with protective items (laboratory overalls, gloves, mask, etc.).
9. The HVJ-E suspension has been confirmed by sterility testing to be free of contamination by bacteria or fungi. However, absence of contamination by all microorganisms cannot be guaranteed and appropriate procedures must be followed when using this product.
10. Freeze-dried HVJ-E and the reconstituted suspension should be stored at 2-8°C. Do not use HVJ-E beyond expiration date on label.
11. The proper use of this product is described in the instructions given in this package insert. Manufacturer (Ishihara Sangyo Kaisha, Ltd.) and distributors are not liable for any accident or damage arising from the use of this product which is not in strict compliance with these instructions
12. This product and its use are covered by the claims of one or more patents (including patents pending) and licensed for research use only. It may not be used for any commercial or other purpose or resold after modification or the like without prior written approval from manufacturer (Ishihara Sangyo Kaisha, Ltd.).

1. Outline

1-1: Principle of transfection

GenomONE™-Neo EX is a non-viral reagent for transfection developed on the basis of the technology described in the following paper.

- Kaneda, Y., *et al.*: Hemagglutinating virus of Japan (HVJ) envelope vector as a versatile gene delivery system. *Molecular Therapy*, **6**, 219-226 (2002).
- Kaneda, Y., *et al.*: New vector innovation for drug delivery: development of fusigenic non-viral particles. *Curr. Drug Targets*, **4**, 599-602 (2003).

The molecule to be transferred (DNA, protein, antisense oligonucleotide, siRNA, etc.) is incorporated in the HVJ-Envelope (HVJ-E) to yield an HVJ-E vector, which is then introduced into the target cell or tissue, making use of the membrane-fusion activity of fusion (F) protein (Fig. 1).

*HVJ: Hemagglutinating Virus of Japan, synonym for Sendai Virus (SeV).

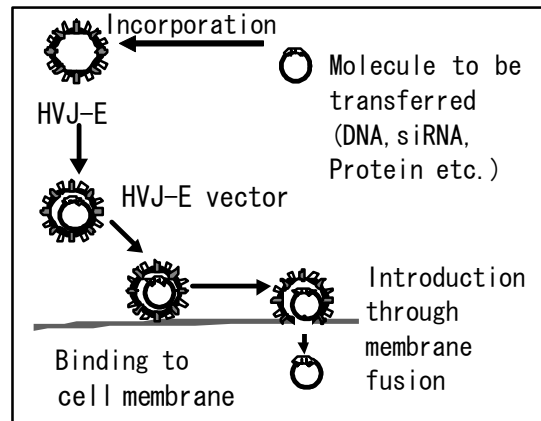

Fig.1 Principle of transfection

1-2: Specifications

Cat. #	Freeze-dried HVJ-E (inactivated HVJ) 0.26 mL /vial (when reconstituted)	Reagent A (enhancer for incorporation) 0.5 mL/vial	Reagent B (reagent for incorporation) 0.3 mL/vial	Reagent C (enhancer for introduction) 1.0 mL/vial	Buffer (for suspension and dilution) 6.5 mL/vial
ISK-GN001EX	1 vial	1 vial	1 vial	1 vial	1 vial
ISK-GN004EX	4 vials	1 vial	1 vial	1 vial	1 vial
ISK-GN040EX	40 vials	10 vials	10 vials	10 vials	10 vials

Storage:

Freeze-dried HVJ-E: Refrigerated at 2-8°C, sealed in an aluminum package. Keep dry.

Reagent A, B, C and Buffer: Refrigerated at 2-8°C.

Reconstituted HVJ-E suspension: Refrigerated at 2-8°C and should be used within 2 weeks. Do not freeze.

[Role of each reagent]

- Freeze-dried HVJ-E: The main frame of the vector into which the molecule to be transferred is included. It fuses with the cell membrane, allowing the target molecule to be introduced into the cytoplasm.
- Reagent A: A positively-charged peptide which increases the affinity between the target molecule and HVJ-E and thus facilitates incorporation of the molecule into HVJ-E.
- Reagent B: Increases permeability across the HVJ-E membrane.
- Reagent C: A positively-charged peptide which increases affinity between the molecule-bearing HVJ-E (HVJ-E vector) and the cell (or tissue) and thus increases the efficiency of transfection.
- Buffer: Neutral buffer of physiological concentration used for suspending or diluting HVJ-E or other purposes.

[Preparation of HVJ-E suspension (reconstitution of freeze-dried HVJ-E)]

- The tube containing freeze-dried HVJ-E is combined with ice-cooled buffer (0.26 mL). The mixture is gently pipetted, with care taken to avoid bubbling. A homogeneous suspension is thus prepared. The HVJ-E suspension gradually loses activity if the temperature is above 8°C. The suspension should be immediately stored in an ice-cooled bath or in a refrigerator (2-8°C).

[Storage, stability, and quality assurance]

- The period of guarantee of quality for freeze-dried HVJ-E is printed on the aluminum package for HVJ-E.
- Because the activity of freeze-dried HVJ-E can be reduced by exposure to high temperature or high relative humidity, refrigerated storage with sealing in an aluminum package is required. After reconstitution, the HVJ-E suspension requires refrigerated storage (2-8°C) and should be used within 2 weeks. Since thawing of frozen suspension can reduce activity, the suspension should not be stored frozen.
- We cannot guarantee the quality of HVJ-E after expiration of the period of guarantee of quality, product stored at temperatures other than those indicated in the instructions, or product subjected to superficial modification, drug treatment, or the like.

[Quality and safety]

- Although HVJ-E uses HVJ (Sendai virus) as a raw material, the genomic RNA of HVJ has been completely inactivated by drug treatment*. The HVJ-E will not proliferate or exhibit pathogenic effects in humans or animals.

*Reference:

Kaneda, Y. *et al.*: "Non-Viral Vectors for Gene Therapy", Advances in Genetics, Vol. 53, pp 308-332, Ed. Huang Leaf, Hung Mien-Chie, Wagner Ernst, Academic Press (2005).

Related article:

Prior, C. *et al.*: BioPharm, 22-33 (Oct. 1996)

! HVJ-E retains membrane-fusion activity. Therefore, to prevent inhalation, attachment, unintended swallowing, or spread to eyes or nose of the HVJ-E particles, the product must be manipulated within a safety cabinet, wearing appropriate clothing (laboratory overalls) and protective items (plastic or latex gloves, mask, protective eyeglasses, etc.).

- Inactivation of HVJ has been confirmed for each lot by the viral proliferative potential rule-out test, using cultured cells and fertilized chicken eggs.
- Absence of contamination by bacteria and fungi has been confirmed by sterility testing.

! Absence of contamination by all microorganisms cannot be guaranteed and appropriate procedures must be followed when using this product.

- Endotoxin level has been confirmed to be less than 2.5 EU/mL (Limulus amoebocyte lysate gel clot assay).
- Expression of the gene introduced in cultured cells (BHK-21; ATCC CCL-10) in the presence of serum has been confirmed.

[Frequency of use]

- If used with the method described in this package insert, the product can be used for transfection as follows (with a 6-well plate).

Cat. #	No. of HVJ-E vials per kit	Cargo to be transfected	
		Plasmid DNA, ODN, protein	siRNA (oligo-type)
ISK-GN001EX	1	6 assays (wells)	25-50 assays (wells)
ISK-GN004EX	4	25 assays (wells)	100-200 assays (wells)
ISK-GN040EX	40	250 assays (wells)	1000-2000 assays (wells)

2. Methods described in this package insert

This package insert describes standard methods for use of this product for transfection of adherent cells, suspension cells, and animals. It also describes protocols for rapid processing of many samples.

Diverse methods are available for use depending on the molecule to be transferred and the destination of transfer. This package insert describes individual steps of transfection (inclusion and transfer) for each molecule to be transferred into each destination (adhesive cells, floating cells, and animals). The inclusion step differs depending on the concentration and type of molecule to be transferred.

2-1: Definition of quantity (AU: Assay Unit)

Amounts of HVJ-E are expressed in AU (Assay Units). One AU is defined as the standard amount (40 μ L) used for transfection with plasmid DNA, using a 6-well plate.

2-2: Recommended cell density for each well plate size

The conditions shown in the protocol pertain to cases in which 6-well plates is used. The cell densities for well plates other than 6-well plates are given below.

2-2-1 : Adherent cells

Plate	Cell density (upon inoculation onto the well plate*)
6-well plate	$0.4 - 2.0 \times 10^5$ cells/2.0 mL of medium/well
24-well plate	$1.0 \sim 5.0 \times 10^4$ cells/0.5mL of medium/well
96-well plate	$0.25 \sim 1.25 \times 10^4$ cells/0.125mL of medium/well

*Used for transfection under conditions of one-day culture and 50-80% confluency.

2-2-2 : Suspension cells

When transfection of suspension cells is performed, the cells are combined with HVJ-E vector in a tube, and the mixture is centrifuged to induce contact between the cells and the vector, leading to transfection.

Plate size	Cell density		
	Centrifugation (in a tube)	Medium for resuspension	Inoculation onto the well plate
6-well	$0.4 \sim 2.0 \times 10^6$ cells/0.5mL of medium/tube	2.0mL	$0.4 \sim 2.0 \times 10^6$ cells/2.0mL of medium/well
24-well	$0.2 \sim 1.0 \times 10^6$ cells/0.25mL of medium/tube	1.0mL	$1.0 \sim 5.0 \times 10^5$ cells/0.5mL of medium/well
96-well			$0.25 \sim 1.25 \times 10^5$ cells/0.125mL of medium/well

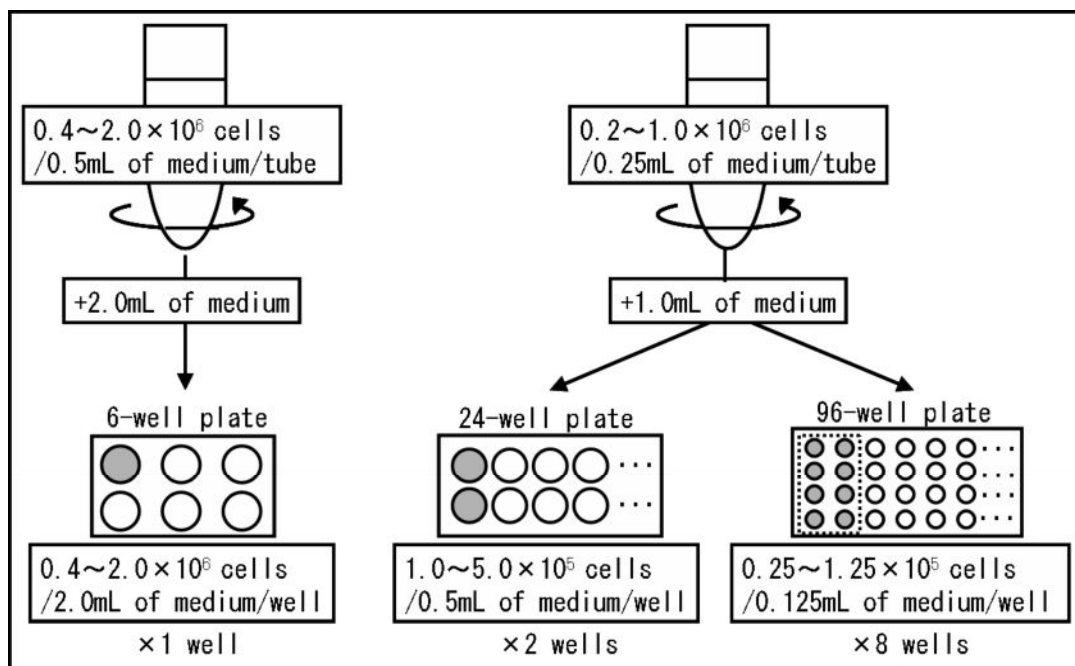

Fig. 2 : Transfection of suspension cells

3. Transfection of adherent cells

3-1: Transfer of plasmid DNA

3-1-1: Recommended protocol

The protocol shown below pertains to the use of 6-well plates. The cell densities for plates of other sizes are given on Page 5.

- Recommended DNA/TE solution concentration: 2-4 $\mu\text{g}/\mu\text{L}$
- Cell density: $0.4\text{-}2.0 \times 10^5$ cells/2.0 mL of medium/well of 6-well plate
- Protocol (Method 2)

Preparation of HVJ-E suspension (reconstitution of freeze-dried HVJ-E)

Ice-cooled buffer (0.26 mL) is added to a tube containing freeze-dried HVJ-E. The mixture is pipetted gently, with care taken to avoid bubbling. A homogeneous suspension is thus prepared and stored refrigerated. Immediately before use, HVJ-E suspension, other reagents, and tubes should be cooled adequately in an ice bath. The vector is then prepared in the following steps.

		Step (keep 0-8 °C)	Amount of reagent
Incorporation	(1)	HVJ-E suspension taken into a micro-test tube	HVJ-E: 1AU (40 μL)
	(2)	Centrifugation at 10,000 g (10,000-12,000 rpm) for 5 minutes at 4°C. Supernatant is discarded.	
	(3)	Suspension in DNA/TE solution (pipetted 20-30 times or more until the suspension becomes uniformly white)	DNA/TE solution: 10-20 μL
	(4)	Combination with Reagent B and agitation ¹ (tapping)	Reagent B: 1-2 μL
	(5)	Centrifugation at 10,000 g (10,000-12,000 rpm) for 5 minutes at 4°C. Supernatant is discarded.	
Introduction	(6)	Sediment suspended in the buffer (pipetted 20-30 times or more until the suspension becomes uniformly white) ²	Buffer: 30 μL
	(7)	Combination with Reagent C and agitation ³ (tapping)	Reagent C: 5 μL
	(8)	HVJ-E vector suspension is combined with the cell culture in a well and incubated at 37°C under 5%CO ₂ (medium renewed as needed) ⁴	Suspension ((6) + (7)): 35 μL
	(9)	Incubated at 37°C under 5%CO ₂ .	

Steps (1) through (7) should be performed on ice.

■ Amount of reagent for each plate

Plate size	Incorporation Step			Introduction Step		
	HVJ-E (1)	DNA/TE soln. (3)	Reagent B (4)	Buffer (6)	Reagent C (7)	Amount of HVJ-E vector to be treated (8)
6-well	1AU (40 μL)	20 μL	2 μL	30 μL	5 μL	35 μL × 1 well
24-well	0.5AU (20 μL)	10 μL	1 μL	15 μL	2.5 μL	8 μL × 2 wells
96-well	0.5AU (20 μL)	10 μL	1 μL	15 μL	2.5 μL	2 μL × 8 wells

¹ The amount of Reagent B added should equal to 1/10 of the fluid volume before addition (Step 3).

² When suspending the sediment in the buffer, the mixture is agitated gently (to avoid bubbling) until the suspension becomes uniformly white. Agitation with a vortex should be avoided since it can cause bubbling. It is advisable to use a pipette for this purpose.

³ The optimal concentration of Reagent C can vary depending on the type of cell. It is advisable to appropriately adjust the amount of Reagent C added (range: 2.5-25 μL) depending on the type of cell used. The volume of buffer (Step 6) should be adjusted to make the final volume of the suspension equal to 35 μL .

⁴ Usually, the medium does not need to be renewed after addition of HVJ-E vector suspension (Steps (6) + (7)). If any sign of cytotoxicity is noted, renew the medium after about 10 minutes to 3 hours of exposure.

3-1-2: Protocol for use of low concentrations of DNA

If the concentration of DNA/TE solution is lower than the recommended concentration (0.5-2 µg/µL), Reagent A is used to promote inclusion of DNA into HVJ-E. The protocol shown below pertains to the use of 6-well plates. The cell densities for plates of other sizes are given on Page 5.

- Recommended DNA/TE concentration: 0.5-2 µg/µL
- Cell density: $0.4-2.0 \times 10^5$ cells/2.0 mL of medium/well of 6-well plate
- Protocol (Method 1)

Preparation of HVJ-E suspension (reconstitution of freeze-dried HVJ-E)

Ice-cooled buffer (0.26 mL) is added to a tube containing freeze-dried HVJ-E. The mixture is pipetted gently, with care taken to avoid bubbling. A homogeneous suspension is thus prepared and stored refrigerated. Immediately before use, HVJ-E suspension, other reagents, and tubes should be cooled adequately in an ice bath. The vector is then prepared in the following steps.

Step (keep 0-8 °C)			Amount of reagent
Incorporation	(1)	HVJ-E suspension taken into a micro-test tube	HVJ-E: 1AU (40 µL)
	(2)	Combination with Reagent A and agitation (tapping). Left to stand on ice for 5 minutes.	Reagent A: 10 µL
	(3)	Suspension in DNA/TE solution (tapping)	DNA/TE solution: 10 µL
	(4)	Combination with Reagent B and agitation ⁵ (tapping)	Reagent B: 6 µL
	(5)	Centrifugation at 10,000 g (10,000-12,000 rpm) for 5 minutes at 4°C. Supernatant is discarded.	
Introduction	(6)	Sediment suspended in the buffer (pipetted 20-30 times or more until the suspension becomes uniformly white) ⁶	Buffer: 30 µL
	(7)	Combination with Reagent C and agitation ⁷ (tapping)	Reagent C: 5 µL
	(8)	HVJ-E vector suspension is combined with the cell culture in a well and incubated at 37°C under 5%CO ₂ (medium renewed as needed) ⁸	Suspension ((6) + (7)): 35 µL
	(9)	Incubated at 37°C under 5%CO ₂ .	

Steps (1) through (7) should be performed on ice.

■ Amount of reagent for each plate

Plate size	Incorporation Step				Introduction Step		
	HVJ-E (1)	Reagent A (2)	DNA/TE soln. (3)	Reagent B (4)	Buffer (6)	Reagent C (7)	Amount of HVJ-E vector to be treated (8)
6-well	1AU (40 µL)	10 µL	10 µL	6 µL	30 µL	5 µL	35 µL × 1 well
24-well	0.5AU (20 µL)	5 µL	5 µL	3 µL	15 µL	2.5 µL	8 µL × 2 wells
96-well	0.5AU (20 µL)	5 µL	5 µL	3 µL	15 µL	2.5 µL	2 µL × 8 wells

⁵ The amount of Reagent B added should equal to 1/10 of the fluid volume before addition (Step 3).

⁶ When suspending the sediment in the buffer, the mixture is agitated gently (to avoid bubbling) until the suspension becomes uniformly white. Agitation with a vortex should be avoided since it can cause bubbling. It is advisable to use a pipette for this purpose.

⁷ The optimal concentration of Reagent C can vary depending on the type of cell. It is advisable to appropriately adjust the amount of Reagent C added (range: 2.5-25 µL) depending on the type of cell used. The volume of buffer (Step 6) should be adjusted to make the final volume of the suspension equal to 35 µL.

⁸ Usually, the medium does not need to be renewed after addition of HVJ-E vector suspension (Steps (6) + (7)). If any sign of cytotoxicity is noted, renew the medium after about 10 minutes to 3 hours of exposure.

3-2: Transfer of siRNA

siRNA (oligo-type) can be used at low concentrations since it exerts activity in cytoplasm and its activity is highly specific. Furthermore, the amount of HVJ-E used can be reduced to 1/4-1/8 (0.25-0.125 AU) of the amount needed with plasmid DNA. The protocol shown below pertains to the use of 6-well plates. The cell densities for plates of other sizes are given on Page 5.

- Recommended siRNA (oligo-type) concentration: 0.1-0.5 µg/µL
- Cell density: 0.4-2.0 × 10⁵ cells/2.0 mL of medium/well of 6-well plate
- Protocol (Method for siRNA)

Preparation of HVJ-E suspension (reconstitution of freeze-dried HVJ-E)

Ice-cooled buffer (0.26 mL) is added to a tube containing freeze-dried HVJ-E. The mixture is pipetted gently, with care taken to avoid bubbling. A homogeneous suspension is thus prepared and stored refrigerated. Immediately before use, HVJ-E suspension, other reagents, and tubes should be cooled adequately in an ice bath. The vector is then prepared in the following steps.

Step (keep 0-8 °C)			Amount of reagent
Incorporation	(1)	HVJ-E suspension taken into a micro-test tube	HVJ-E: 0.25AU (10 µL)
	(2)	Combination with siRNA solution and agitation ⁹ (tapping)	SiRNA solution: 10 µL
	(3)	Combination with Reagent B and agitation ¹⁰ (tapping)	Reagent B: 2 µL
	(4)	Centrifugation at 10,000 g (10,000-12,000 rpm) for 5 minutes at 4°C. Supernatant is discarded.	
Introduction	(5)	Sediment suspended in the buffer (pipetted 20-30 times or more until the suspension becomes uniformly white) ¹¹	Buffer: 30 µL
	(6)	Combination with Reagent C and agitation ¹² (tapping)	Reagent C: 5 µL
	(7)	HVJ-E vector suspension is combined with the cell culture in a well and incubated at 37°C under 5%CO ₂ (medium renewed as needed) ¹³	Suspension ((5) + (6)): 35 µL
	(8)	Incubated at 37°C under 5%CO ₂ .	

Steps (1) through (6) should be performed on ice.

■ Amount of reagent for each plate

Plate size	Incorporation Step			Introduction Step		
	HVJ-E (1)	SiRNA soln. (2)	ReagentB (3)	Buffer (5)	Reagent C (6)	Amount of HVJ-E vector to be treated (7)
6-well	0.25AU (10 µL)	10 µL	2 µL	30 µL	5 µL	35 µL × 1 well
24-well	0.125AU (5 µL)	5 µL	1 µL	15 µL	2.5 µL	8 µL × 2 wells
96-well	0.125AU (5 µL)	5 µL	1 µL	15 µL	2.5 µL	2 µL × 8 wells

● One-point advice

The optimal amount of HVJ-E can vary depending on the type of cell used or the target gene. If efficiency of transfer or knock-down is low, adjust the amount of HVJ-E used in Step 1 within the range between 1 AU (40 µL) and 0.125 AU (5 µL) to optimize conditions. At that time, the amount of Reagent B added needs to be adjusted to 1/10 of the volume of the fluid before addition (Steps 1 + 2).

⁹ The amount of Reagent B added should equal to 1/10 of the fluid volume before addition (Step 3).

¹⁰ The amount of Reagent B added is equal to 1/10 of the fluid volume before addition (Step 3).

¹¹ When suspending the sediment in the buffer, the mixture is agitated gently (to avoid bubbling) until the suspension becomes uniformly white. Agitation with a vortex should be avoided since it can cause bubbling. It is advisable to use a pipette for this purpose.

¹² The optimal concentration of Reagent C can vary depending on the type of cell. It is advisable to appropriately adjust the amount of Reagent C added (range: 2.5-25 µL) depending on the type of cell used. The volume of buffer (Step 5) should be adjusted to make the final volume of the suspension equal to 35 µL.

¹³ Usually, the medium does not need to be renewed after addition of HVJ-E vector suspension (Steps (6) + (7)). If any sign of cytotoxicity is noted, renew the medium after about 10 minutes to 3 hours of exposure.

3-3: Transfer of antisense oligo/decoy-oligo (ODN)

The protocol shown below pertains to the use of 6-well plates. The cell densities for plates of other sizes are given on Page 5.

- Recommended ODN concentration: 0.5-2 $\mu\text{g}/\mu\text{L}$
- Cell density: $0.4\text{-}2.0 \times 10^5$ cells/2.0 mL of medium/well of 6-well plate
- Protocol (Method 1)

Preparation of HVJ-E suspension (reconstitution of freeze-dried HVJ-E)

Ice-cooled buffer (0.26 mL) is added to a tube containing freeze-dried HVJ-E. The mixture is pipetted gently, with care taken to avoid bubbling. A homogeneous suspension is thus prepared and stored refrigerated. Immediately before use, HVJ-E suspension, other reagents, and tubes should be cooled adequately in an ice bath. The vector is then prepared in the following steps.

Step (keep 0-8 °C)			Amount of reagent
Incorporation	(1)	HVJ-E suspension taken into a micro-test tube	HVJ-E: 1AU (40 μL)
	(2)	Combination with Reagent A and agitation (tapping). Left to stand on ice for 5 minutes.	Reagent A: 10 μL
	(3)	Suspension in DNA/TE solution (tapping)	DNA/TE solution: 10 μL
	(4)	Combination with Reagent B and agitation ¹⁴ (tapping)	Reagent B: 6 μL
	(5)	Centrifugation at 10,000 g (10,000-12,000 rpm) for 5 minutes at 4°C. Supernatant is discarded.	
Introduction	(6)	Sediment suspended in the buffer (pipetted 20-30 times or more until the suspension becomes uniformly white) ¹⁵	Buffer: 30 μL
	(7)	Combination with Reagent C and agitation ¹⁶ (tapping)	Reagent C: 5 μL
	(8)	HVJ-E vector suspension is combined with the cell culture in a well and incubated at 37°C under 5%CO ₂ (medium renewed as needed) ¹⁷	Suspension ((6) + (7)): 35 μL
	(9)	Incubated at 37°C under 5%CO ₂ .	

Steps (1) through (7) should be performed on ice.

■ Amount of reagent for each plate

Plate size	Incorporation Step				Introduction Step		
	HVJ-E (1)	Reagent A (2)	ODN soln. (3)	Reagent B (4)	Buffer (6)	Reagent C (7)	Amount of HVJ-E vector to be treated (8)
6-well	1AU (40 μL)	10 μL	10 μL	6 μL	30 μL	5 μL	35 $\mu\text{L} \times 1$ well
24-well	0.5AU (20 μL)	5 μL	5 μL	3 μL	15 μL	2.5 μL	8 $\mu\text{L} \times 2$ wells
96-well	0.5AU (20 μL)	5 μL	5 μL	3 μL	15 μL	2.5 μL	2 $\mu\text{L} \times 8$ wells

¹⁴ The amount of Reagent B added should equal to 1/10 of the fluid volume before addition (Step 3).

¹⁵ When suspending the sediment in the buffer, the mixture is agitated gently (to avoid bubbling) until the suspension becomes uniformly white. Agitation with a vortex should be avoided since it can cause bubbling. It is advisable to use a pipette for this purpose.

¹⁶ The optimal concentration of Reagent C can vary depending on the type of cell. It is advisable to appropriately adjust the amount of Reagent C added (range: 2.5-25 μL) depending on the type of cell used. The volume of buffer (Step 6) should be adjusted to make the final volume of the suspension equal to 35 μL .

¹⁷ Usually, the medium does not need to be renewed after addition of HVJ-E vector suspension (Steps (6) + (7)). If any sign of cytotoxicity is noted, renew the medium after about 10 minutes to 3 hours of exposure.

3-4: Transfer of protein

The protocol shown below pertains to the use of 6-well plates. The cell densities for plates of other sizes are given on Page 5.

- Recommended protein concentration: 0.5-2 µg/µL
- Cell density: 0.4-2.0 × 10⁵ cells/2.0 mL of medium/well of 6-well plate
- Protocol (Method 1)

Preparation of HVJ-E suspension (reconstitution of freeze-dried HVJ-E)

Ice-cooled buffer (0.26 mL) is added to a tube containing freeze-dried HVJ-E. The mixture is pipetted gently, with care taken to avoid bubbling. A homogeneous suspension is thus prepared and stored refrigerated. Immediately before use, HVJ-E suspension, other reagents, and tubes should be cooled adequately in an ice bath. The vector is then prepared in the following steps.

		Step (keep 0-8 °C)	Amount of reagent
Incorporation	(1)	HVJ-E suspension taken into a micro-test tube	HVJ-E: 1AU (40 µL)
	(2)	Centrifugation at 10,000 g (10,000-12,000 rpm) for 5 minutes at 4°C. Supernatant is discarded.	
	(3)	Sediment suspended in the buffer (pipetted 20-30 times or more until the suspension becomes uniformly white) ¹⁸	Buffer: 40 µL
	(4)	Combination with Reagent A and agitation (tapping). Left to stand on ice for 5 minutes.	Reagent A: 10 µL
	(5)	Combination with protein solution and agitation (tapping).	Protein solution: 10 µL
	(6)	Combination with Reagent B and agitation ¹⁹ (tapping)	Reagent B: 6 µL
	(7)	Centrifugation at 10,000 g (10,000-12,000 rpm) for 5 minutes at 4°C. Supernatant is discarded.	
Introduction	(8)	Sediment suspended in the buffer (pipetted 20-30 times or more until the suspension becomes uniformly white)	Buffer: 30 µL
	(9)	Combination with Reagent C and agitation ²⁰ (tapping)	Reagent C: 5 µL
	(10)	HVJ-E vector suspension is combined with the cell culture in a well and incubated at 37°C under 5%CO ₂ (medium renewed as needed) ²¹	Suspension ((8) + (9)): 35 µL
	(11)	Incubated at 37°C under 5%CO ₂ .	

Steps (1) through (9) should be performed on ice.

Steps (2) and (3) are designed to eliminate the preservatives contained in the freeze-dried HVJ-E.

■ Amount of reagent for each plate

Plate size	Incorporation Step				Introduction Step		
	HVJ-E (3)	Reagent A (4)	Protein soln. (5)	Reagent B (6)	Buffer (8)	Reagent C (9)	Amount of HVJ-E vector to be treated (10)
6-well	1AU (40 µL)	10 µL	10 µL	6 µL	30 µL	5 µL	35 µL × 1 well
24-well	0.5AU (20 µL)	5 µL	5 µL	3 µL	15 µL	2.5 µL	8 µL × 2 wells
96-well	0.5AU (20 µL)	5 µL	5 µL	3 µL	15 µL	2.5 µL	2 µL × 8 wells

● One-point advice

When positively-charged protein is used, try either reducing the amount of Reagent A added in Incorporation Step (2) (to 1/2 to 1/8) or skipping the addition of Reagent A. At that time, the amount of Reagent B added in Step (4) needs to be adjusted to 1/10 of the volume before addition (Steps (3) + (4) + (5)).

¹⁸ When suspending the sediment in the buffer, the mixture is agitated gently (to avoid bubbling) until the suspension becomes uniformly white. Agitation with a vortex should be avoided since it can cause bubbling. It is advisable to use a pipette for this purpose.

¹⁹ The amount of Reagent B added should equal to 1/10 of the fluid volume before addition (Step 3).

²⁰ The optimal concentration of Reagent C can vary depending on the type of cell. It is advisable to appropriately adjust the amount of Reagent C added (range: 2.5-25 µL) depending on the type of cell used.

The volume of buffer (Step 8) should be adjusted to make the final volume of the suspension equal to 35 µL.

²¹ Usually, the medium does not need to be renewed after addition of HVJ-E vector suspension (Steps (8) + (9)). If any sign of cytotoxicity is noted, renew the medium after about 10 minutes to 3 hours of exposure.

3-5: Troubleshooting

■ Low efficiency of transfection

Efficiency may be increased by the following measures:

- Increase the amount of Reagent C two- to four-fold compared to the standard amount.
- Reduce the amount of medium used for transfection and increase the concentrations of HVJ-E vector and Reagent C.
- Centrifuge the mixture of HVJ-E vector and cells in the plate at 1,500-3,000 rpm for 10-60 minutes at a temperature of 35°C (4°C to room temperature for some types of cells).
- Check the purity of nucleic acid. Plasmid DNA used for transfection should be of high quality. Endotoxin level should also be reduced by using appropriate purification tools.

■ High cytotoxicity

If any sign of cytotoxicity is noted, cytotoxicity may be reduced by the following measures:

- Wash the HVJ-E vector 10 minutes to 3 hours after addition to the cells, and renew the medium.
- Reduce the amount of HVJ-E used or the amount of HVJ-E vector added to the medium.
- Endotoxin level should also be reduced by using appropriate removing tools.

4. Transfection of suspension cells

4-1: Transfer of plasmid DNA

4-1-1: Recommended protocol

When transfection of floating cells is attempted, the mixture of HVJ-E and cells is centrifuged to increase the efficiency of exposure. The protocol shown below pertains to the use of 6-well plates. The cell densities for plates of other sizes are given on Page 5.

- Recommended DNA/TE solution concentration: 2-4 $\mu\text{g}/\mu\text{L}$
- Cell density: $0.4\text{-}2.0 \times 10^6$ cells/0.5 mL of medium/tube
- Protocol (Method 2, modified)

Preparation of HVJ-E suspension (reconstitution of freeze-dried HVJ-E)

Ice-cooled buffer (0.26 mL) is added to a tube containing freeze-dried HVJ-E. The mixture is pipetted gently, with care taken to avoid bubbling. A homogeneous suspension is thus prepared and stored refrigerated. Immediately before use, HVJ-E suspension, other reagents, and tubes should be cooled adequately in an ice bath. The vector is then prepared in the following steps.

		Step (keep 0-8 °C)	Amount of reagent
Incorporation	(1)	HVJ-E suspension taken into a micro-test tube	HVJ-E: 1AU (40 μL)
	(2)	Centrifugation at 10,000 g (10,000-12,000 rpm) for 5 minutes at 4°C. Supernatant is discarded.	
	(3)	Suspension in DNA/TE solution (pipetted 20-30 times or more until the suspension becomes uniformly white)	DNA/TE solution: 10-20 μL
	(4)	Combination with Reagent B and agitation ²² (tapping)	Reagent B: 1-2 μL
	(5)	Centrifugation at 10000 g (10000-12000 rpm) for 5 minutes at 4°C. Supernatant is discarded.	
Introduction	(6)	Sediment suspended in the buffer (pipetted 20-30 times or more until the suspension becomes uniformly white) ²³	Buffer: 30 μL
	(7)	Combination with Reagent C and agitation ²⁴ (tapping)	Reagent C: 5 μL
	(8)	HVJ-E vector suspension is combined with the cells suspended in medium (0.5 mL) in a tube.	Suspension (Steps (6) + (7)):35 μL + Cell: 0.5 mL
	(9)	Centrifugation at 2,000-12,000 rpm for 10-30 minutes at 4-35°C ²⁵ .	
	(10)	The supernatant is discarded. The cells are resuspended in 2.0 mL medium and transferred to a 6-well plate for incubation at 37°C under 5%CO ₂ .	Medium for resuspension: 2.0 mL

Steps (1) through (7) should be performed on ice.

- Amount of reagent for each plate

Plate size	Incorporation Step			Introduction Step			
	HVJ-E (1)	DNA/TE (3)	Reagent B (4)	Buffer (6)	Reagent C (7)	Cell (8)	Medium for resuspension (10)
6-well	1AU (40 μL)	20 μL	2 μL	30 μL	5 μL	0.5mL	2.0mL (2.0mL \times 1well)
24-well	0.5AU (20 μL)	10 μL	1 μL	15 μL	2.5 μL	0.25mL	1.0mL (0.5mL \times 2 wells)
96-well	0.5AU (20 μL)	10 μL	1 μL	15 μL	2.5 μL	0.25mL	1.0mL (0.125mL \times 8 wells)

²² The amount of Reagent B added should equal to 1/10 of the fluid volume before addition (Step 3).

²³ When suspending the sediment in the buffer, the mixture is agitated gently (to avoid bubbling) until the suspension becomes uniformly white. Agitation with a vortex should be avoided since it can cause bubbling. It is advisable to use a pipette for this purpose.

²⁴ The optimal concentration of Reagent C can vary depending on the type of cell. It is advisable to appropriately adjust the amount of Reagent C added (range: 2.5-25 μL) depending on the type of cell used. The volume of buffer (Step 6) should be adjusted to make the final volume of the suspension equal to 35 μL .

²⁵ The conditions of centrifugation (rate of rotation, temperature, and duration) may be adjusted within the range not causing cell damage.

4-1-2 : Protocol for use of low concentrations of DNA

If the concentration of DNA/TE solution is lower than the recommended concentration (0.5-2 $\mu\text{g}/\mu\text{L}$), Reagent A is used to promote inclusion of DNA into HVJ-E. The protocol shown below pertains to the use of 6-well plates. The cell densities for plates of other sizes are given on Page 5.

- Recommended DNA/TE concentration: 0.5-2 $\mu\text{g}/\mu\text{L}$
- Cell density: $0.4\text{-}2.0 \times 10^6$ cells/0.5 mL of medium/tube
- Protocol (Method 1)

Preparation of HVJ-E suspension (reconstitution of freeze-dried HVJ-E)

Ice-cooled buffer (0.26 mL) is added to a tube containing freeze-dried HVJ-E. The mixture is pipetted gently, with care taken to avoid bubbling. A homogeneous suspension is thus prepared and stored refrigerated. Immediately before use, HVJ-E suspension, other reagents, and tubes should be cooled adequately in an ice bath. The vector is then prepared in the following steps.

Step (keep 0-8 °C)			Amount of reagent
Incorporation	(1)	HVJ-E suspension taken into a micro-test tube	HVJ-E: 1AU (40 μL)
	(2)	Combination with Reagent A and agitation (tapping). Store on ice for 5 minutes.	Reagent A: 10 μL
	(3)	Suspension in DNA/TE solution (tapping)	DNA/TE solution: 10 μL
	(4)	Combination with Reagent B and agitation ²⁶ (tapping)	Reagent B: 6 μL
	(5)	Centrifugation at 10,000 g (10,000-12,000 rpm) for 5 minutes at 4°C. Supernatant is discarded.	
Introduction	(6)	Sediment suspended in the buffer (pipetted 20-30 times or more until the suspension becomes uniformly white) ²⁷	Buffer: 30 μL
	(7)	Combination with Reagent C and agitation ²⁸ (tapping)	Reagent C: 5 μL
	(8)	HVJ-E vector suspension is combined with the cells suspended in medium (0.5 mL) in a tube.	Suspension (Steps (6) + (7)): 35 μL + Cell: 0.5 mL
	(9)	Centrifugation at 2,000-12,000 rpm for 10-30 minutes at 4-35°C ²⁹ .	
	(10)	The supernatant is discarded. The cells are resuspended in 2.0 mL medium and transferred to a 6-well plate for incubation at 37°C under 5%CO ₂ .	Medium for resuspension: 2.0 mL

Steps (1) through (7) should be performed on ice.

■ Amount of reagent for each plate

Plate size	Incorporation Step				Introduction Step			
	HVJ-E (1)	Reagent A (2)	DNA/TE Soln. (3)	Reagent B (4)	Buffer (6)	Reagent C (7)	Cell (8)	Medium for resuspension (10)
6-well	1AU (40 μL)	10 μL	10 μL	6 μL	30 μL	5 μL	0.5mL	2.0mL (2.0mL \times 1 well)
24-well	0.5AU (20 μL)	5 μL	5 μL	3 μL	15 μL	2.5 μL	0.25mL	1.0mL (0.5mL \times 2 wells)
96-well	0.5AU (20 μL)	5 μL	5 μL	3 μL	15 μL	2.5 μL	0.25mL	1.0mL (0.125mL \times 8 wells)

²⁶ The amount of Reagent B added should equal to 1/10 of the fluid volume before addition (Step 3).

²⁷ When suspending the sediment in the buffer, the mixture is agitated gently (to avoid bubbling) until the suspension becomes uniformly white. Agitation with a vortex should be avoided since it can cause bubbling. It is advisable to use a pipette for this purpose.

²⁸ The optimal concentration of Reagent C can vary depending on the type of cell. It is advisable to appropriately adjust the amount of Reagent C added (range: 2.5-25 μL) depending on the type of cell used. The volume of buffer (Step 6) should be adjusted to make the final volume of the suspension equal to 35 μL .

²⁹ The conditions of centrifugation (rate of rotation, temperature, and duration) may be adjusted within the range not causing cell damage.

4-2: Transfer of siRNA

SiRNA (oligo-type) can be used at low concentrations since it exerts activity in cytoplasm and its activity is highly specific. Furthermore, the amount of HVJ-E used can be reduced to 1/4-1/8 (0.25-0.125 AU) of the amount needed with plasmid DNA. The protocol shown below pertains to the use of 6-well plates. The cell densities for plates of other sizes are given on Page 5.

- Recommended siRNA (oligo-type) concentration: 0.1-0.5 $\mu\text{g}/\mu\text{L}$
- Cell density: $0.4\text{-}2.0 \times 10^6$ cells/0.5 mL of medium/tube
- Protocol (Method for siRNA, modified)

Preparation of HVJ-E suspension (reconstitution of freeze-dried HVJ-E)

Ice-cooled buffer (0.26 mL) is added to a tube containing freeze-dried HVJ-E. The mixture is pipetted gently, with care taken to avoid bubbling. A homogeneous suspension is thus prepared and stored refrigerated. Immediately before use, HVJ-E suspension, other reagents, and tubes should be cooled adequately in an ice bath. The vector is then prepared in the following steps.

Step (keep 0-8 °C)			Amount of reagent
Incorporation	(1)	HVJ-E suspension taken into a micro-test tube	HVJ-E: 0.25AU (10 μL)
	(2)	Combination with siRNA solution and agitation (tapping)	SiRNA solution: 10 μL
	(3)	Combination with Reagent B and agitation ³⁰ (tapping)	Reagent B: 2 μL
	(4)	Centrifugation at 10,000 g (10,000-12,000 rpm) for 5 minutes at 4°C. Supernatant is discarded.	
Introduction	(5)	Sediment suspended in the buffer (pipetted 20-30 times or more until the suspension becomes uniformly white) ³¹	Buffer: 30 μL
	(6)	Combination with Reagent C and agitation ³² (tapping)	Reagent C: 5 μL
	(7)	HVJ-E vector suspension is combined with the cells suspended in medium (0.5 mL) in a tube.	Suspension (Steps (5) + (6)):35 μL + Cell: 0.5 mL
	(8)	Centrifugation at 2,000-12,000 rpm for 10-30 minutes at 4-35°C ³³ .	
	(9)	The supernatant is discarded. The cells are resuspended in 2.0 mL medium and transferred to a 6-well plate for incubation at 37°C under 5%CO ₂ .	Medium for resuspension: 2.0 mL

Steps (1) through (6) should be performed on ice.

■ Amount of reagent for each plate

Plate size	Incorporation Step			Introduction Step			
	HVJ-E (1)	SiRNA soln. (2)	Reagent B (3)	Buffer (5)	Reagent C (6)	Cell (7)	Medium for resuspension (9)
6-well	0.25AU(10 μL)	10 μL	2 μL	30 μL	5 μL	0.5mL	2.0mL (2.0mL \times 1 well)
24-well	0.125AU(5 μL)	5 μL	1 μL	15 μL	2.5 μL	0.25mL	1.0mL (0.5mL \times 2 wells)
96-well	0.125AU(5 μL)	5 μL	1 μL	15 μL	2.5 μL	0.25mL	1.0mL (0.125mL \times 8 wells)

● One-point advice

The optimal amount of HVJ-E can vary depending on the type of cell used or the target gene. If efficiency of transfer or knock-down is low, adjust the amount of HVJ-E used in Step 1 within the range between 1 AU (40 μL) and 0.125 AU (5 μL) to optimize conditions. At that time, the amount of Reagent B added needs to be adjusted to 1/10 of the volume of the fluid before addition (Steps (1) + (2)).

³⁰ The amount of Reagent B added should equal to 1/10 of the fluid volume before addition (Step 3).

³¹ When suspending the sediment in the buffer, the mixture is agitated gently (to avoid bubbling) until the suspension becomes uniformly white. Agitation with a vortex should be avoided since it can cause bubbling. It is advisable to use a pipette for this purpose.

³² The optimal concentration of Reagent C can vary depending on the type of cell. It is advisable to appropriately adjust the amount of Reagent C added (range: 2.5-25 μL) depending on the type of cell used. The volume of buffer (Step 5) should be adjusted to make the final volume of the suspension equal to 35 μL .

³³ The conditions of centrifugation (rate of rotation, temperature, and duration) may be adjusted within the range not causing cell damage.

4-3: Transfer of antisense oligo/decoy-oligo (ODN)

The protocol shown below pertains to the use of 6-well plates. The cell densities for plates of other sizes are given on Page 5.

- Recommended ODN concentration: 0.5-2 µg/µL
- Cell density: $0.4-2.0 \times 10^6$ cells/0.5 mL of medium/tube
- Protocol (Method 1, modified)

Preparation of HVJ-E suspension (reconstitution of freeze-dried HVJ-E)

Ice-cooled buffer (0.26 mL) is added to a tube containing freeze-dried HVJ-E. The mixture is pipetted gently, with care taken to avoid bubbling. A homogeneous suspension is thus prepared and stored refrigerated. Immediately before use, HVJ-E suspension, other reagents, and tubes should be cooled adequately in an ice bath. The vector is then prepared in the following steps.

		Step (keep 0-8 °C)	Amount of reagent
Incorporation	(1)	HVJ-E suspension taken into a micro-test tube	HVJ-E: 1AU (40 µL)
	(2)	Combination with Reagent A and agitation (tapping). Left to stand on ice for 5 minutes.	Reagent A: 10 µL
	(3)	Suspension in ODN solution (tapping)	DNA/TE solution: 10 µL
	(4)	Combination with Reagent B and agitation ³⁴ (tapping)	Reagent B: 6 µL
	(5)	Centrifugation at 10,000 g (10,000-12,000 rpm) for 5 minutes at 4°C. Supernatant is discarded.	
Introduction	(6)	Sediment suspended in the buffer (pipetted 20-30 times or more until the suspension becomes uniformly white) ³⁵	Buffer: 30 µL
	(7)	Combination with Reagent C and agitation ³⁶ (tapping)	Reagent C: 5 µL
	(8)	HVJ-E vector suspension is combined with the cells suspended in medium (0.5 mL) in a tube.	Suspension (Steps (6) + (7)): 35 µL + Cell: 0.5 mL
	(9)	Centrifugation at 2,000-12,000 rpm for 10-30 minutes at 4-35°C ³⁷ .	
	(10)	The supernatant is discarded. The cells are resuspended in 2.0 mL medium and transferred to a 6-well plate for incubation at 37°C under 5%CO ₂ .	Medium for resuspension: 2.0 mL

Steps (1) through (7) should be performed on ice.

■ Amount of reagent for each plate

Plate size	Incorporation Step				Introduction Step			
	HVJ-E (1)	Reagent A (2)	ODN soln. (3)	Reagent B (4)	Buffer (6)	Reagent C (7)	Cell (8)	Medium for resuspension (10)
6-well	1AU (40 µL)	10 µL	10 µL	6 µL	30 µL	5 µL	0.5mL	2.0mL (2.0mL × 1well)
24-well	0.5AU (20 µL)	5 µL	5 µL	3 µL	15 µL	2.5 µL	0.25mL	1.0mL (0.5mL × 2 wells)
96-well	0.5AU (20 µL)	5 µL	5 µL	3 µL	15 µL	2.5 µL	0.25mL	1.0mL (0.125mL × 8 wells)

³⁴ The amount of Reagent B added should equal to 1/10 of the fluid volume before addition (Step 3).

³⁵ When suspending the sediment in the buffer, the mixture is agitated gently (to avoid bubbling) until the suspension becomes uniformly white. Agitation with a vortex should be avoided since it can cause bubbling. It is advisable to use a pipette for this purpose.

³⁶ The optimal concentration of Reagent C can vary depending on the type of cell. It is advisable to appropriately adjust the amount of Reagent C added (range: 2.5-25 µL) depending on the type of cell used. The volume of buffer (Step 6) should be adjusted to make the final volume of the suspension equal to 35 µL.

³⁷ The conditions of centrifugation (rate of rotation, temperature, and duration) may be adjusted within the range not causing cell damage.

4-4: Transfer of protein

The protocol shown below pertains to the use of 6-well plates. The cell densities for plates of other sizes are given on Page 5.

- Recommended protein concentration: 0.5-2 µg/µL
- Cell density: 0.4-2.0 × 10⁶ cells/0.5 mL of medium/tube
- Protocol (Method 1, modified)

Preparation of HVJ-E suspension (reconstitution of freeze-dried HVJ-E)

Ice-cooled buffer (0.26 mL) is added to a tube containing freeze-dried HVJ-E. The mixture is pipetted gently, with care taken to avoid bubbling. A homogeneous suspension is thus prepared and stored refrigerated. Immediately before use, HVJ-E suspension, other reagents, and tubes should be cooled adequately in an ice bath. The vector is then prepared in the following steps.

		Step (keep 0-8 °C)	Amount of reagent
Incorporation	(1)	HVJ-E suspension taken into a micro-test tube	HVJ-E: 1AU (40 µL)
	(2)	Centrifugation at 10,000 g (10,000-12,000 rpm) for 5 minutes at 4°C. Supernatant is discarded.	
	(3)	Sediment suspended in the buffer (pipetted 20-30 times or more until the suspension becomes uniformly white) ³⁸	Buffer: 40 µL
	(4)	Combination with Reagent A and agitation (tapping). Left to stand on ice for 5 minutes.	Reagent A: 10 µL
	(5)	Combination with protein solution and agitation (tapping).	Protein solution: 10 µL
	(6)	Combination with Reagent B and agitation ³⁹ (tapping)	Reagent B: 6 µL
	(7)	Centrifugation at 10,000 g (10,000-12,000 rpm) for 5 minutes at 4°C. Supernatant is discarded.	
Introduction	(8)	Sediment suspended in the buffer (pipetted 20-30 times or more until the suspension becomes uniformly white)	Buffer: 30 µL
	(9)	Combination with Reagent C and agitation ⁴⁰ (tapping)	Reagent C: 5 µL
	(10)	HVJ-E vector suspension is combined with the cells suspended in medium (0.5 mL) in a tube.	Suspension (Steps (8) + (9)): 35 µL + Cell: 0.5 mL
	(11)	Centrifugation at 2,000-12,000 rpm for 10-30 minutes at 4-35°C ⁴¹ .	
	(12)	The supernatant is discarded. The cells are resuspended in 2.0 mL medium and transferred to a 6-well plate for incubation at 37°C under 5%CO ₂ .	Medium for resuspension: 2.0 mL

Steps (1) through (9) should be performed on ice.

Steps (2) and (3) are designed to eliminate the preservatives contained in the freeze-dried HVJ-E.

■ Amount of reagent for each plate

Plate size	Incorporation Step				Introduction Step			
	HVJ-E (3)	Reagent A (4)	Protein soln. (5)	Reagent B (6)	Buffer (8)	Reagent C (9)	Cell (10)	Medium for resuspension (12)
6-well	1AU(40 µL)	10 µL	10 µL	6 µL	30 µL	5 µL	0.5mL	2.0mL (2.0mL × 1well)
24-well	0.5AU(20 µL)	5 µL	5 µL	3 µL	15 µL	2.5 µL	0.25mL	1.0mL (0.5mL × 2 wells)
96-well	0.5AU(20 µL)	5 µL	5 µL	3 µL	15 µL	2.5 µL	0.25mL	1.0mL (0.125mL × 8 wells)

● One-point advice

When positively-charged protein is used, try either reducing the amount of Reagent A added in Incorporation Step (2) (to 1/2 to 1/8) or skipping the addition of Reagent A. At that time, the amount of Reagent B added in Step (4) needs to be adjusted to 1/10 of the volume before addition (Steps (3) + (4) + (5)).

³⁸ When suspending the sediment in the buffer, the mixture is agitated gently (to avoid bubbling) until the suspension becomes uniformly white. Agitation with a vortex should be avoided since it can cause bubbling. It is advisable to use a pipette for this purpose.

³⁹ The amount of Reagent B added should equal to 1/10 of the fluid volume before addition (Step 3).

⁴⁰ The optimal concentration of Reagent C can vary depending on the type of cell. It is advisable to appropriately adjust the amount of Reagent C added (range: 2.5-25 µL) depending on the type of cell used. The volume of buffer (Step 8) should be adjusted to make the final volume of the suspension equal to 35 µL.

⁴¹ The conditions of centrifugation (rate of rotation, temperature, and duration) may be adjusted within the range not causing cell damage.

4-5: Troubleshooting

■ Low efficiency of transfection

Efficiency may be increased by the following measures:

- Increase the amount of Reagent C to two- to four-fold to the standard amount.
- Reduce the amount of medium used for transfection and increase the concentrations of HVJ-E vector and Reagent C.
- Extend the duration of centrifugation of the mixture of HVJ-E vector and cells to about 60 minutes.
- Check the purity of nucleic acid. Plasmid DNA used for transfection should be of high quality. Endotoxin level should also be reduced by using appropriate purification tools.

■ High cytotoxicity

If any sign of cytotoxicity is noted, cytotoxicity may be reduced by the following measures:

- Shorten the duration of centrifugation after the addition of HVJ-E vector to the cells to the minimum (10 minutes) and set the temperature during centrifugation at 4°C.
- Reduce the amount of HVJ-E used or the amount of HVJ-E vector added to the medium.
- Reduce the amount of Reagent C added (or skip use of this reagent).
- Endotoxin level should also be reduced by using appropriate removing tools.

5. Transfection of laboratory animals (*in vivo*)

The protocol shown below pertains to an example in which transfection of mouse organs or tissue (direct injection to organs or tissue) *in vivo* is attempted. The method of administration, dose level, etc., can vary markedly depending on the species of animals, the type or location of the target organ, and other factors. These conditions may need to be adjusted in individual cases.

5-1: Transfer of plasmid DNA or siRNA

- Recommended DNA/TE concentration: 1 µg/µL
- Recommended siRNA concentration: 1 µg/µL
- Protocol (In vivo Method M)

Preparation of HVJ-E suspension (reconstitution of freeze-dried HVJ-E)

Ice-cooled buffer (0.26 mL) is added to a tube containing freeze-dried HVJ-E. The mixture is pipetted gently, with care taken to avoid bubbling. A homogeneous suspension is thus prepared and stored refrigerated. Immediately before use, HVJ-E suspension, other reagents, and tubes should be cooled adequately in an ice bath. The vector is then prepared in the following steps.

		Step (keep 0-8 °C)	Amount of reagent
Incorporation	(1)	HVJ-E suspension taken into a micro-test tube	HVJ-E: 1AU (40 µL)
	(2)	Combination with Reagent B and agitation ⁴² (tapping)	Reagent B: 4 µL
	(3)	Centrifugation at 10,000 g (10,000-12,000 rpm) and 4°C for 10 minutes. Supernatant is discarded.	
	(4)	Sediment suspended in the buffer (pipetted 20-30 times or more until the suspension becomes uniformly white) ⁴³	Buffer, physiological saline, or the like: 10 µL
	(5)	Combination with DNA/TE solution or siRNA solution and agitation (tapping)	DNA/TE or siRNA solution: 10 µL
	(6)	Left to stand for 5 minutes	
Administration	(7)	HVJ-E vector suspension administered to animals (after dilution with physiological saline, etc., as needed)	Dose level: Adjusted tailored to the objective
	(8)	Subsequent evaluation (preparation of specimens, microscopy, etc.)	

Steps (1) through (9) should be performed on ice.

● One-point advice

- The amount of HVJ-E is approximately 1-2 AU for mice and 5-10 AU for rats. The amount of each reagent used in subsequent steps also needs to be adjusted in proportion to the amount of HVJ-E used.
- Depending on the features of the experimental system (the site of administration, route of administration, etc.), dose level must be adjusted appropriately by adding buffer, physiological saline, or the like to the HVJ-E vector suspension (Step (6)).
- When this product is used in animals, it is as a rule advisable to skip treatment with Reagent C. If the substance introduced needs to be retained in tissue near the site of injection, you may add Reagent C to HVJ-E vector suspension (Step (6)).
- Because HVJ-E can be easily adsorbed onto blood cells and be inactivated *in vivo*, it is advisable to select a route of administration involving less exposure to blood (direct injection to organs or tissue is recommended) or to perform perfusion of the animal prior to administration.

⁴² The amount of Reagent B added should equal to 1/10 of the fluid volume before addition (Step 3).

⁴³ When suspending the sediment in the buffer, the mixture is agitated gently (to avoid bubbling) until the suspension becomes uniformly white. Agitation with a vortex should be avoided since it can cause bubbling. It is advisable to use a pipette for this purpose.

5-2: Transfer of antisense oligo/decoy-oligo (ODN) and protein

- Recommended ODN concentration: 0.5-2 $\mu\text{g}/\mu\text{L}$
- Recommended protein concentration: 0.5-2 $\mu\text{g}/\mu\text{L}$
- Protocol (In vivo Method 1)

Preparation of HVJ-E suspension (reconstitution of freeze-dried HVJ-E)

Ice-cooled buffer (0.26 mL) is added to a tube containing freeze-dried HVJ-E. The mixture is pipetted gently, with care taken to avoid bubbling. A homogeneous suspension is thus prepared and stored refrigerated. Immediately before use, HVJ-E suspension, other reagents, and tubes should be cooled adequately in an ice bath. The vector is then prepared in the following steps.

		Step (keep 0-8 °C)	Amount of reagent
Incorporation	(1)	HVJ-E suspension taken into a micro-test tube	HVJ-E: 1AU (40 μL)
	(2)	Combination with Reagent A and agitation (tapping). Left to stand for 5 minutes.	Reagent A: 10 μL
	(3)	Combination with ODN or protein solution and agitation (tapping)	ODN or protein solution: 10 μL
	(4)	Combination with Reagent B and agitation ⁴⁴ (tapping)	Reagent B: 6 μL
	(5)	Centrifugation at 10,000 g (10,000-12,000 rpm) and 4°C for 5 minutes. Supernatant is discarded.	
Administration	(6)	Sediment suspended in the buffer (pipetted 20-30 times or more until the suspension becomes uniformly white) ⁴⁵	Use of a buffer, physiological saline, or the like, tailored to the experimental system.
	(7)	HVJ-E vector suspension administered to animals (after dilution with physiological saline, etc., as needed)	Dose level: Adjusted depending on the objective
	(8)	Subsequent evaluation (preparation of specimens, microscopy, etc.)	

Steps (1) through (6) should be performed on ice.

For incorporation of protein, the preservatives must be removed by centrifugation in accordance with Steps 1 through 3 of incorporation procedure (Page 10).

● One-point advice

- The amount of HVJ-E is approximately 1-2 AU for mice and 5-10 AU for rats. The amount of each reagent used in subsequent steps also needs to be adjusted in proportion to the amount of HVJ-E used.
- Depending on the features of the experimental system (the site of administration, route of administration, etc.), dose level must be adjusted appropriately by adding buffer, physiological saline, or the like to the HVJ-E vector suspension (Step (6)).
- When this product is used in animals, it is as a rule advisable to skip treatment with Reagent C. If the substance introduced needs to be retained in tissue near the site of injection, you may add Reagent C to HVJ-E vector suspension (Step (6)).
- Because HVJ-E can be easily adsorbed onto blood cells and be inactivated in vivo, it is advisable to select a route of administration involving less exposure to blood (direct injection to organs or tissue is recommended) or to perform perfusion of the animal prior to administration.
- In case of abnormal turbidity or non-homogeneous sedimentation in the solution prepared in Step (3), try either increasing the purity of the ODN/protein to be added or reducing the amount of Reagent A (Step (2)) to 1/2-1/8 or skipping use of Reagent A. At that time, the amount of Reagent B (Step (4)) needs to be adjusted to 1/10 of the volume before addition (Steps (1) + (2) + (3)).
- When positively-charged protein is used, try either reducing the amount of Reagent A added in Inclusion Step (2) (to 1/2 to 1/8) or skipping the addition of Reagent A. At that time, the amount of Reagent B added in Step (4) needs to be adjusted to 1/10 of the volume before addition (Steps (1) + (2) + (3)).

⁴⁴ The amount of Reagent B added should equal to 1/10 of the fluid volume before addition (Step 3).

⁴⁵ When suspending the sediment in the buffer, the mixture is agitated gently (to avoid bubbling) until the suspension becomes uniformly white. Agitation with a vortex should be avoided since it can cause bubbling. It is advisable to use a pipette for this purpose.

6. Rapid transfection for multiple types of and numerous samples

Treatment of HVJ-E with Reagent B prior to inclusion of contents enables preparation of competent HVJ-E, and makes it possible to rapidly include various types of content in HVJ-E. For example, if a 96-well plate is used, transfection with 96 different types of content can be completed in about 30 minutes. This technique is suitable when high throughput is required, i.e., cases in which multiple genes, siRNAs, etc., need to be treated rapidly on the same plate for analysis of cell function or exploration of new genes.

If plates of other sizes are used, transfection with this product is possible by adjusting the dose level on the basis of well area ratio.

6-1: Transfer of plasmid DNA

- DNA/TE solution concentration: 0.1-0.25 $\mu\text{g}/\mu\text{L}$
- Cell density: $0.2\text{-}1.0 \times 10^4$ cells/0.1 ml of medium/well of 96-well plate
- Protocol (Method M)

The protocol shown below pertains to the use of 96-well plates.

* This method assumes transfection of adhesive cells.

Preparation of HVJ-E suspension (reconstitution of freeze-dried HVJ-E)

Ice-cooled buffer (0.26 mL) is added to a tube containing freeze-dried HVJ-E. The mixture is pipetted gently, with care taken to avoid bubbling. A homogeneous suspension is thus prepared and stored refrigerated. Immediately before use, HVJ-E suspension, other reagents, and tubes should be cooled adequately in an ice bath. The vector is then prepared in the following steps.

		Step (with a 96-well plate)	keep 0-8 °C	Amount of reagent
Incorporation	(1)	HVJ-E suspension taken into a micro-test tube		HVJ-E: 6.25AU (250 μL)
	(2)	Combination with Reagent B and agitation ⁴⁶ (tapping)		Reagent B: 25 μL
	(3)	Centrifugation at 10,000 g (10,000-12,000 rpm) ant 4°C for 10 minutes. Supernatant is discarded ⁴⁷		
	(4)	Sediment suspended in buffer (pipetted 20-30 times or more until the suspension becomes uniformly white) ⁴⁸		Buffer: 500 μL
	(5)	Suspension prepared in Step 4 is applied to 96-well plate ⁴⁹ for vector preparation.		5 $\mu\text{L}/\text{well}$
	(6)	DNA/TE solution is added to each well and agitated (with a plate shaker, etc.)		5 $\mu\text{L}/\text{well}$
	(7)	Left to stand for 5 minutes		
Introduction	(8)	Reagent C, diluted 1:16 (Reagent C 35 μL + buffer 525 μL), is added and agitated (with a plate shaker, etc.)		Diluted Reagent C: 5 $\mu\text{L}/\text{well}$
	(9)	Medium is added to each well and agitated (with a plate shaker, etc.)		Medium: 50 $\mu\text{L}/\text{well}$
	(10)	HVJ-E vector suspension added to each well of another 96-well plate containing preincubated cells, and incubated at 37°C under 5% CO ₂ (medium renewed as needed). ⁵⁰		Suspension (Steps (5) + (6) + (8) + (9)): 65 $\mu\text{L}/\text{well}$
	(11)	Incubation at 37°C under 5%CO ₂		

Steps (1) through (4) should be performed on ice.

⁴⁶ The amount of Reagent B added should equal 1/10 of the volume before addition (Step (1)).

⁴⁷ With this technique, the HVJ-E pellets obtained after centrifugation are likely to collapse. Care is needed to avoid aspirating the pellets when discarding the supernatant.

⁴⁸ When suspending the sediment in the buffer, the mixture is agitated gently (to avoid bubbling) until the suspension becomes uniformly white. Agitation with a vortex should be avoided since it can cause bubbling. It is advisable to use a pipette for this purpose.

⁴⁹ For the process of incorporation into HVJ-E, a plate other than that for incubation of the cells to be transfected should be used.

⁵⁰ Usually, the medium does not need to be renewed after addition of HVJ-E vector suspension (Steps (5) + (6) + (8) + (9)). If any sign of cytotoxicity is noted, renew the medium after about 10 minutes to 3 hours of exposure.

6-2 : Transfer of siRNA

- SiRNA (oligo-type) concentration: 0.01-0.05 $\mu\text{g}/\mu\text{L}$
- Cell density: $0.2\text{-}1.0 \times 10^4$ cells/0.1 ml of medium/well of 96-well plate
- Protocol (Method M for siRNA)

The protocol shown below pertains to the use of 96-well plates.

* This method assumes transfection of adhesive cells.

Preparation of HVJ-E suspension (reconstitution of freeze-dried HVJ-E)

Ice-cooled buffer (0.26 mL) is added to a tube containing freeze-dried HVJ-E. The mixture is pipetted gently, with care taken to avoid bubbling. A homogeneous suspension is thus prepared and stored refrigerated. Immediately before use, HVJ-E suspension, other reagents, and tubes should be cooled adequately in an ice bath. The vector is then prepared in the following steps.

		Step (with a 96-well plate) keep 0-8 °C	Amount of reagent
Incorporation	(1)	HVJ-E suspension taken into a micro-test tube	HVJ-E: 1.75AU (70 μL)
	(2)	Combination with Reagent B and agitation ⁵¹ (tapping)	Reagent B: 7 μL
	(3)	Centrifugation at 10,000 g (10,000-12,000 rpm) ant 4°C for 10 minutes. Supernatant is discarded ⁵²	
	(4)	Sediment suspended in buffer (pipetted 20-30 times or more until the suspension becomes uniformly white) ⁵³	Buffer: 560 μL
	(5)	Suspension prepared in Step 4 is applied to 96-well plate ⁵⁴ for vector preparation.	5 $\mu\text{L}/\text{well}$
	(6)	siRNA solution is added to each well and agitated (with a plate shaker, etc.)	5 $\mu\text{L}/\text{well}$
	(7)	Left to stand for 5 minutes	
Introduction	(8)	Reagent C, diluted 1:16 (Reagent C 35 μL + buffer 525 μL), is added and agitated (with a plate shaker, etc.)	Diluted Reagent C: 5 $\mu\text{L}/\text{well}$
	(9)	Medium is added to each well and agitated (with a plate shaker, etc.)	Medium: 50 $\mu\text{L}/\text{well}$
	(10)	HVJ-E vector suspension added to each well of another 96-well plate containing preincubated cells, and incubated at 37°C under 5% CO ₂ (medium renewed as needed). ⁵⁵	Suspension (Steps (5) + (6) + (8) + (9)): 65 $\mu\text{L}/\text{well}$
	(11)	Incubation at 37°C under 5%CO ₂	

Steps (1) through (4) should be performed on ice.

⁵¹ The amount of Reagent B added should equal 1/10 of the volume before addition (Step (1)).

⁵² With this technique, the HVJ-E pellets obtained after centrifugation are likely to collapse. Care is needed to avoid aspirating the pellets when discarding the supernatant.

⁵³ When suspending the sediment in the buffer, the mixture is agitated gently (to avoid bubbling) until the suspension becomes uniformly white. Agitation with a vortex should be avoided since it can cause bubbling. It is advisable to use a pipette for this purpose.

⁵⁴ For the process of incorporation into HVJ-E, a plate other than that for incubation of the cells to be transfected should be used.

⁵⁵ Usually, the medium does not need to be renewed after addition of HVJ-E vector suspension (Steps (5) + (6) + (8) + (9)). If any sign of cytotoxicity is noted, renew the medium after about 10 minutes to 3 hours of exposure.

Troubleshooting Guide for *GenomONE-Neo EX*

Problem	Possible cause
Low transfection efficiency	Loss of binding or fusion activity of HVJ-E. (in vitro, in vivo)
	Low efficiency of binding of HVJ-E with target cell membrane. (in vitro)
	Low efficiency of incorporation of nucleic acids into HVJ-E. (in vitro, in vivo)
	Nucleic acids of poor quality. (in vitro, in vivo)
	Cell density is not adequate. (in vitro)
	Molecular size of content is too small (Mw.< 1kDa) or too large. (in vitro, in vivo)
High cytotoxicity (In vitro)	Excessive exposure of cells to HVJ-E vector.
	Plasmid DNA preparation contaminated with large amount of endotoxin.
	Excessive exposure of cells to Reagent C.
	Conditions of cultured cells are not suitable for transfection.
	If above checks or tests prove negative and do not result in any improvement, HVJ-E vector may be extremely cytotoxic to your specific cell type.

FAQ for *GenomONE-Neo EX*

	Questions
1	Characteristics of HVJ-E
2	Principle of transfection
3	Differences in mechanism of transfection between HVJ-E vector and other existing non-viral transfection reagents (cationic liposomes etc.)
4	Restriction for GenomONE-Neo EX use
5	Expiration date
6	Particle size of HVJ-E How large is this carrier HVJ envelope vector?
7	Method for inactivation of HVJ
8	Assessment and confirmation of viral inactivation
9	Methods for confirmation of viral inactivation
10	Bio-safety level for laboratory use
11	Safety evaluation of HVJ-liposomes in nonhuman primates
12	Quality assurance
13	License requirement and commercial use
14	Role of each Reagent
15	Constituent and concentration of each Reagent
16	Storage of reconstituted HVJ-E suspension
17	Storage of Reagent A, B, C and Buffer
18	Number of HVJ-E particles included in 1 Assay Unit (AU) of HVJ-E suspension
19	Hemagglutination units (HAU) of HVJ-E included in 1 Assay Unit (AU) of HVJ-E suspension
20	Efficiency of incorporation into HVJ-E
21	Limit of size of DNA that can be incorporated into HVJ-E
22	Limit of size of protein or synthetic compounds that can be incorporated into HVJ-E
23	Possibility of storage of HVJ-E vector after incorporation of plasmid DNA, siRNA, ODN or protein.
24	Recommended cell density for each well plate size
25	Frequency of use (in vitro)
26	Effects of serum and antibiotics in the medium during transfection (In vitro)
27	Efficiency of transfection of circular DNA and linear DNA (In vitro)
28	Efficiency of transfection of mRNAs (In vitro)
29	Frequency of use (in vivo/ laboratory animals)
30	Precautions for in vivo transfection (route of administration)
31	Immunogenicity in vivo. Consecutive administration in vivo
32	Effects of mouse or rat lineage on efficiency of transfection
33	Published researches using GenomONE

NOTE



ISHIHARA SANGYO KAISHA, LTD.

E-Mail: HVJ-E@iskweb.co.jp

URL: <http://www.iskweb.co.jp/hvj-e>